

**PART I: MULTIPLE CHOICE QUESTIONS (150 points)**

(Mark A, B, C or D on your answer sheet to indicate the correct answer to each of the following questions)

**Question 1:** A moto moves with a uniform motion. During the first of the distance 15km with the time is 0,75h, the second of the distance is 12 km with the time is 0,25h. The average velocity of the whole distance is

- A. 25 km/h.      B. 48 km/h.      C. 32,5 km/h.      D. 27 km/h.

**Question 2:** The formula for liquid pressure.

- A.  $P = d.h$ .      B.  $p = d.h$ .      C.  $p = D.h$ .      D.  $p = d.V$ .

**Question 3:** The object weighing 3kg falls from a tree to the ground 2m below. Calculate the work of the gravity.

- A. 3J.      B. 6J.      C. 60J.      D. 600J.

**Question 4:** The magnitude of Archimedes's propulsive force is calculated with the formula:  $F_A = d.V$ , where  $d$  is the specific weight of with the liquid, what is  $V$ ? which of following answers is **wrong**?

- A.  $V$  is the volume of the water portion occupied by the piece of wood.  
B.  $V$  is the volume of the piece of wood.  
C.  $V$  is the volume of the wooden part sunk in water.  
D.  $V$  is the volume crossed in the Figure 1.

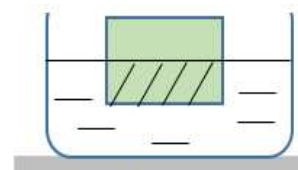

figure 1

**Question 5:** The primary form of heat transfer of the solid:

- A. conduction.      B. convection.      C. radiation.      D. All B and C are true.

**Question 6:** Drop a 0,15 kg copper the object which is heat up to 200°C into a glass of water at 20°C. After a moment, the temperature of the object and the water is the same 50°C. Calculate the water mass, considering that only the object and water transmit heat to each other. Know that the specific heat of copper is 380 J/kg.K, of water is 4200 J/kg.K.

- A. 0,68kg.      B. 0,068kg.      C. 0,7kg.      D. 0,086kg.

**Question 7:** When put on the two ends of the wire with a voltage of 12V, the current flowing through it is 0,2A. If the voltage applied to the two ends of the wire increases to 48V, the current flowing through it is

- A. 0,6A.      B. 0,7 A.      C. 0,8 A.      D. 0,9 A.

**Question 8:** Given a circuit with the diagram as shown in figure 2 where  $R_1 = 10 \Omega$ . When  $K$  is closed, the voltmerer indicates 15V, the ammeter indicates 0,5A. Caculate the value of the resistance  $R_2$ .

- A.  $10 \Omega$ .      B.  $20 \Omega$ .  
C.  $30 \Omega$ .      D.  $40 \Omega$ .

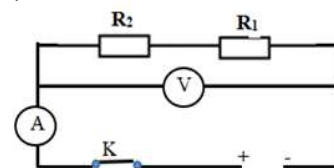

figure 2

**Question 9:** Given the resistance  $R_1$  parallel the resistance  $R_2 = 10 \Omega$ , the ammeter  $A_1$  measure the current passing through  $R_1$ , the ammeter  $A$  measure the current main. Know the ammeter  $A_1$  indicates 0,5A; the ammeter  $A$  indicates 1,5A. The voltage applied to two ends of the conductor.

- A. 5V.      B. 15V.      C. 20V.      D. 10V.

**Question 10:** Project a beam of narrow light onto a plane mirror so that it matches the plane mirror at a  $30^\circ$  angle. The total of the incident angle and the reflective angle is

- A.  $30^\circ$ .                      B.  $40^\circ$ .                      C.  $50^\circ$ .                      D.  $60^\circ$ .

**Question 11:** The following oxides given:  $\text{CaO}$ ,  $\text{Fe}_2\text{O}_3$ ,  $\text{SO}_3$ ,  $\text{N}_2\text{O}_5$ . Oxide can not react with water?

- A.  $\text{SO}_3$ .                      B.  $\text{CaO}$ .                      C.  $\text{N}_2\text{O}_5$ .                      D.  $\text{Fe}_2\text{O}_3$ .

**Question 12:** Oxide of an element with valence II contains 20% oxygen (by mass). That element is:

- A. Copper.                      B. Aluminum.                      C. Calcium.                      D. Magnesium.

**Question 13:** Which one can not be dried by calcium oxide?

- A.  $\text{CO}$ .                      B.  $\text{CO}_2$ .                      C.  $\text{N}_2$ .                      D.  $\text{H}_2$ .

**Question 14:** For 6,5 grams of Zinc in hydrochloric solution, the volume of  $\text{H}_2$  gas released (standard specification) is:

- A. 2 liters.                      B. 4,48 liters.                      C. 2,24 liters.                      D. 4 liters.

**Question 15:** Aluminum burning in oxygen produces aluminum oxide  $\text{Al}_2\text{O}_3$ . When 54 grams of aluminum are burned in excess oxygen. The moles of  $\text{Al}_2\text{O}_3$  produced is

- A. 0,5 mol.                      B. 0,75 mol.                      C. 1,5 mol.                      D. 1 mol.

**Question 16:** The following oxides:  $\text{CaO}$ ,  $\text{SO}_2$ ,  $\text{Fe}_2\text{O}_3$ ,  $\text{Na}_2\text{O}$ ,  $\text{CO}_2$ ,  $\text{P}_2\text{O}_5$ . The series of oxides reacting with water to produce acids are:

- A.  $\text{CaO}$ ,  $\text{SO}_2$ ,  $\text{Fe}_2\text{O}_3$ .                      B.  $\text{SO}_2$ ,  $\text{Na}_2\text{O}$ ,  $\text{CaO}$ .  
C.  $\text{SO}_2$ ,  $\text{CO}_2$ ,  $\text{P}_2\text{O}_5$ .                      D.  $\text{CO}_2$ ,  $\text{Fe}_2\text{O}_3$ ,  $\text{P}_2\text{O}_5$ .

**Question 17:** Mix 1 liter of 1,5M  $\text{NaOH}$  solution with 3 liters of 0,5M  $\text{NaOH}$  solution. The molar concentration of the  $\text{NaOH}$  solution after mixing is:

- A. 0,75M.                      B. 0,85M.                      C. 0,70M.                      D. 0,80M.

**Question 18:** To dissolve complete 20 grams of  $\text{CuO}$  and  $\text{Fe}_2\text{O}_3$  mixed powder needed 200 ml of 3,5M  $\text{HCl}$  solution. The percentage concentration of  $\text{CuO}$  and  $\text{Fe}_2\text{O}_3$  in the mixture is:

- A. 20% và 80%.                      B. 30% và 70%.  
C. 50% và 50%.                      D. 40% và 60%.

**Question 19.** Giving the following substances:  $\text{H}_2\text{SO}_4$ ,  $\text{CuO}$ ,  $\text{SO}_2$ ,  $\text{H}_2\text{O}$ ,  $\text{Mg}$ . The number of pairs of substances which can react to each other is:

- A. 2.                      B. 3.                      C. 4.                      D. 5.

**Question 20:** To distinguish between  $\text{BaCl}_2$  and  $\text{NaCl}$  we use

- A.  $\text{H}_2\text{O}$ .                      B.  $\text{AgNO}_3$  solution.                      C.  $\text{H}_2\text{SO}_4$  solution.                      D.  $\text{NaOH}$  solution.

**Question 21.** Mendel's unique research method is that:

- A. cross a trait pair.                      B. cross 2 trait pairs.  
C. hybrid analysis.                      D. analysis of hybrid generations.

**Question 22.** Which of the following is an analytic hybrid?

- A.  $\text{Aa} \times \text{AA}$ .                      B.  $\text{Aa} \times \text{Aa}$ .                      C.  $\text{Aa} \times \text{aa}$ .                      D.  $\text{AA} \times \text{Aa}$ .

**Question 23.** The genetic factor corresponding to the concept in modern genetics is:

- A. trait.                      B. DNA.                      C. chromosome.                      D. Gene.

**Question 24.** When P: AaBb x AaBb is given F1, the phenotypic ratio is:

- A. 1 : 1.                      B. 9 : 3 : 3 : 1.                      C. 3 : 3 : 1 : 1.                      D. 3 : 1.

**Question 25.** When cross-pollination between trees with round, early ripening fruits and trees with long, late ripening fruits. The phenotype of the following crossbreed is considered as a hybrid:

- A. Round, late ripening fruit.                      B. Round, early ripening fruit.  
C. Long, late ripening fruit.                      D. no.

**Question 26.** To determine the purity of the breed, we implement the method:

- A. crosses with another homozygous organism    B. crosses different lines.  
C. cross-pollination.                      D. hybrid analysis.

**Question 27.** In tomato, red fruit trait is dominant over yellow fruit trait. For purebred red tomato plants, analyzed and obtained F1. For F1 to self-pollinate, the result of F2 is:

- A. 75% red fruit : 25% yellow fruit.                      B. Whole yellow fruit.  
C. 50% yellow fruit: 50% red fruit.                      D. The whole fruit is red.

**Question 28.** If the dominant gene is completely dominant, which of the following genotypes has the same phenotype?

- A. Aabb and aabb.    B. AaBb and Aabb.    C. AaBb and AABB.    D. aaBb and aabb.

**Question 29.** In fruit flies  $2n = 8$ . A cell of fruit flies is in the middle stage of mitosis, the number and status of chromosomes in that cell is:

- A. 16 single chromosomes.                      B. 16 double chromosomes.  
C. 8 single chromosomes.                      D. 8 double chromosomes.

**Question 30.** A leaf bud cell of a plant species( $2n = 14$ ), after division produces daughter cells with

- A. 7 double chromosomes.                      B. 7 single chromosomes.  
C. 14 double chromosomes.                      D. 28 single chromosomes.

**PART II: WRITING QUESTIONS (150 points)**

**Question 31:** Given a circuit with the diagram as shown

Where the resistance  $R_1 = 10\Omega$ ,  $R_2 = 20\Omega$ ,  $R_3 = 30\Omega$ .

The Voltage  $U_{AB} = 44V$ . Caculate the value of the equivalent resistance  $R_{er}$  and the value current passing through each resistor:

- a) With K open.                      b) With K close.

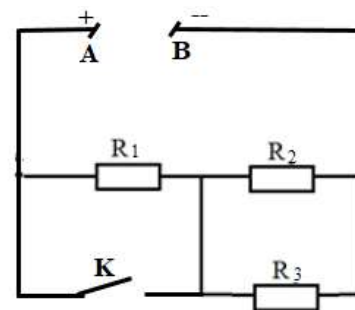

**Question 32:**

a) Complete the following chemical transformations by writing chemical equations.

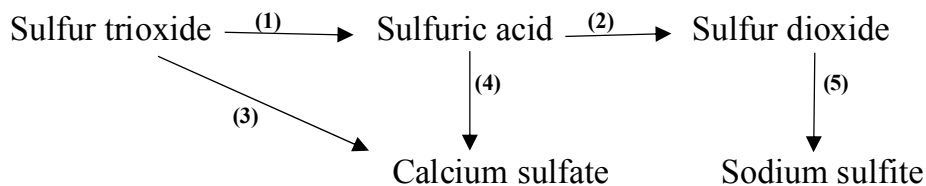

**b)** To dissolve 3,9 grams of metal X, it is necessary to use V (ml) of HCl solution and have 1,344 liters of H<sub>2</sub> (standard specification). On the other hand, to dissolve 3,2 grams of metal Y oxide, it is also necessary to use V (ml) of HCl solution above. What metals are X and Y?

*(H = 1; Cu = 64; Zn = 65; O = 16; Fe = 56; K = 39; Cl = 35,5; Al = 27; Na = 23)*

**Question 33:** In fruit flies, there are  $2n = 8$  chromosomes. In a cell of a mitotic species, it is observed that there are 4 double chromosomes lined up on the equatorial plane of the achromatic spindle.

**a)** What phase of cell division is this cell in? Explain?

**b)** If the cell of the species above undergoes mitosis, determine: The number of centromeres, the number of double chromosome, and the number of single chromosomes in meiosis and posterior mitosis.

=====THE END=====